

COGNEX®

DataMan® 50/60 Control Box

Reference Guide

DATAMAN
ID Readers

About the DataMan Control Box

The DataMan Control Box provides additional functionalities when connected to a DataMan 50 or 60.

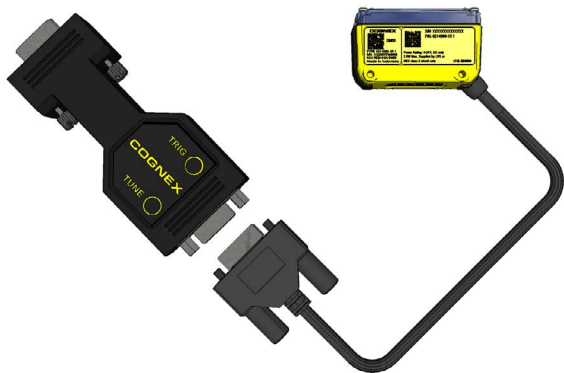

The DataMan Control Box has two buttons and a buzzer. The buttons are connected to Input lines 0 and 1 on the DataMan 50 and 60. The buzzer is connected on the Output 0 line.

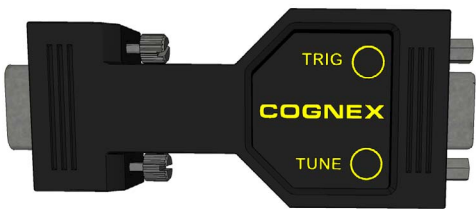

Input Line Options

Input Line 0 is hardwired to Trigger On. You can decide what you connect Input Line 1 (the TUNE button) to, by checking a functionality on the *System Settings* pane's *Inputs* tab's Input line 1.

To use the buttons on the Control Box, change the default Manual trigger mode on the *Light and Imager Settings* pane to any trigger mode other than Manual and Presentation. Press the TUNE button and then the TRIG button in order for the functionality connected to the TUNE button to work.

Button	Inputs	Outputs	Output Delay
Actions			
Trigger On	<input checked="" type="checkbox"/>	<input type="checkbox"/>	
Trigger Off	<input checked="" type="checkbox"/>	<input type="checkbox"/>	
Train Code	<input type="checkbox"/>	<input checked="" type="checkbox"/>	
Optimize Brightness	<input type="checkbox"/>	<input checked="" type="checkbox"/>	
Set Match String	<input type="checkbox"/>	<input type="checkbox"/>	
Read Configuration Code	<input type="checkbox"/>	<input type="checkbox"/>	
Allow Buffered No-Read Images	<input type="checkbox"/>	<input type="checkbox"/>	

Action		
Open	<input type="radio"/>	<input type="radio"/>
Closed	<input checked="" type="radio"/>	<input checked="" type="radio"/>
Pulse Width [ms]	<input type="text" value="5"/>	<input type="text" value="5"/>

The default buzzer duration is 5 ms. On the *System Settings* pane's *Outputs* tab, you can set it to maximum 10000 ms.

For demonstration purposes, the recommended settings for DataMan 50 or 60 Input 1 options are Train Code and Optimize Brightness checked (others unchecked), Pulse Width 50 ms.

Limitations

The following limitations apply when the Control Box is connected to a DataMan 50 or a DataMan 60.

- Output-0 and Output-1 can only be used in sink mode (low side switch). Output-Common is connected to GND inside the Control Box. For reference, see the following image, which shows the pinout of the I/O cable on the DataMan 50 and 60.

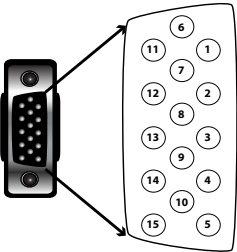

PIN	Color	Signal
1	Brown	Reserved
2	Green	TxD
3	Green/Black	RxD
4	Red	GND
5	Brown/White	DC+ (system power, 5-24 VDC)
6	Blue	RTS
7	Blue/White	Output-0
8	White	Input-0
9	White/Black	Input-1
10	Light Blue	CTS
11	Light Blue/Black	Output-1
12	Light Blue/Yellow	Output-Common (GND)
13	Light Blue/Green	Output-Strobe
14	Yellow	Reserved
15	Yellow/Black	Reserved

- Load connected to Output-0 is limited. The maximum current for 5V supply voltage is 20mA, for 24V it is 1mA. The maximum load current for Output 0 can be calculated by $I_{load_max} = 25mA - (V_{supply} / 1\ k\Omega)$
- Output-Strobe can only be used in TTL mode, not in Open collector mode. The maximum load current at Output-Strobe is reduced by 4mA.

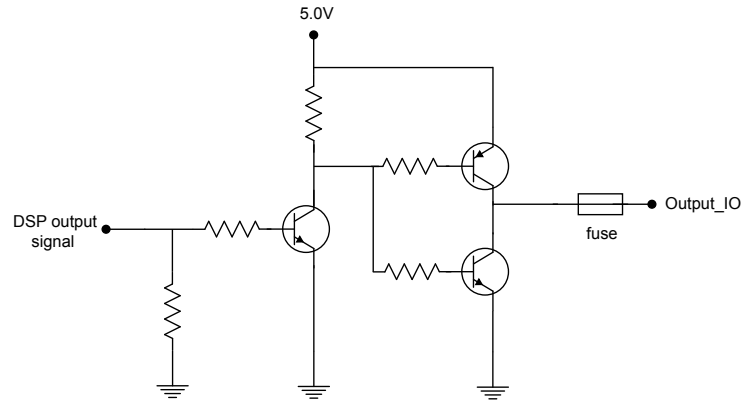

Compliance Statements

The DataMan Control Box meets or exceeds the requirements of all applicable standards organizations for safe operation. However, as with any electrical equipment, the best way to ensure safe operation is to operate them according to the agency guidelines that follow. Please read these guidelines carefully before using your device.

Regulator	Specification
USA	FCC Part 15, Subpart B, Class A
Canada	ICES-003, Class A
European Community	EN55022:2006 +A1:2007, Class A EN55024:1998 +A1:2001 +A2:2003
Australia	C-TICK, AS/NZS CISPR 22 / EN 55022 for Class A Equipment
Japan	J55022, Class A

FCC Class A Compliance Statement



This equipment has been tested and found to comply with the limits for a Class A digital device, pursuant to Part 15 of the FCC rules. These limits are designed to provide reasonable protection against harmful interference when the equipment is operated in a commercial environment. This equipment generates, uses, and can radiate radio frequency energy and, if not installed and used in accordance with the instructions, may cause harmful interference to radio communications. Operation of this

equipment in a residential area is likely to cause harmful interference, in which case the user will be required to correct the interference at personal expense.

Canadian Compliance

This Class A digital apparatus complies with Canadian ICES-003.

Cet appareil numérique de la classe A est conforme à la norme NMB-003 du Canada.

C-Tick Statement



Conforms to AS/NZS CISPR 22/ EN 55022 for Class A Equipment.

European Compliance



The CE mark on the product indicates that the system has been tested to and conforms to the provisions noted within the 2004/108/EEC Electromagnetic Compatibility Directive.

For further information please contact:

Cognex Corporation
One Vision Drive
Natick, MA 01760
USA

Cognex Corporation shall not be liable for use of our product with equipment (i.e., power supplies, personal

computers, etc.) that is not CE marked and does not comply with the Low Voltage Directive.

For European Community Users

Cognex complies with Directive 2002/96/EC OF THE EUROPEAN PARLIAMENT AND OF THE COUNCIL of 27 January 2003 on waste electrical and electronic equipment (WEEE).

This product has required the extraction and use of natural resources for its production. It may contain hazardous substances that could impact health and the environment, if not properly disposed.

In order to avoid the dissemination of those substances in our environment and to diminish the pressure on the natural resources, we encourage you to use the appropriate take-back systems for product disposal. Those systems will reuse or recycle most of the materials of the product you are disposing in a sound way.



The crossed out wheeled bin symbol informs you that the product should not be disposed of along with municipal waste and invites you to use the appropriate separate take-back systems for product disposal.

If you need more information on the collection, reuse, and recycling systems, please contact your

local or regional waste administration.

You may also contact your supplier for more information on the environmental performance of this product.

Copyright © 2013 Cognex Corporation All Rights Reserved. This document may not be copied in whole or in part, nor transferred to any other media or language, without the written permission of Cognex Corporation. The hardware and portions of the software described in this document may be covered by one or more of the U.S. patents listed on the Cognex web site <http://www.cognex.com/patents.asp>. Other U.S. and foreign patents are pending. Cognex, the Cognex logo, and DataMan are trademarks, or registered trademarks, of Cognex Corporation.